

Model:

TVM-36SL-HC~VM01

Visual Merchandiser:

Slim Line Refrigerator with Hydrocarbon Refrigerant



TVM-36SL-HC~VM01

- ▶ Factory engineered system using environmentally friendly R290 hydro carbon refrigerant
 - ▶ High capacity forced air refrigeration system that holds temperature of 0.5°C to 3.3°C
 - ▶ Exterior - non-peel or chip black powder coated cold rolled steel; durable and permanent.
 - ▶ Interior - NSF approved, white aluminum interior liner with stainless steel floor.
 - ▶ Self closing doors. Counter-balanced weight system for smooth, even, positive closing.
 - ▶ "Low-E", double pane thermal insulated glass door assemblies with mitered plastic channel frames. The latest in energy efficient technology.
 - ▶ LED interior lighting provides more even lighting throughout the cabinet. Safety shielded.
 - ▶ Entire cabinet structure is foamed-in-place using a high density, environmentally friendly, polyurethane insulation.
 - ▶ Glass door assemblies with low profile door frame.
- Bottom mounted units feature:**
- ▶ "No stoop" lower shelf
 - ▶ Storage on top of cabinet
 - ▶ Compressor performs in coolest, most grease free area of kitchen
 - ▶ Easily accessible condenser coil for cleaning

PLAN VIEW

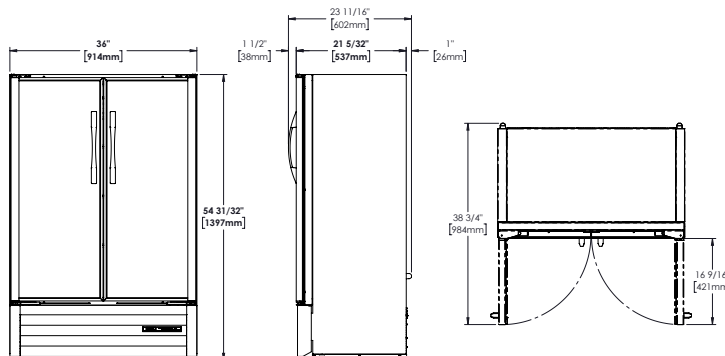

ROUGH-IN DATA

Voltage: 220-240V/50Hz

Specifications subject to change without notice. Chart dimensions rounded up to the next whole millimeter (inches rounded up to the next 1/8").

Model	Doors	Shelves	Cabinet Dimensions (mm)			Total Display Area (m ²)	EEC	EEI	Temperature Class	Annual Energy Consumption (kWh)	Crated Weight (kg)
			W	D †	H						
TVM-36SL-HC~VM01	2	4	915	537	1397	0,74	B	16,5	M1	1048	118

† Depth does not include 38 mm for door handles. † Depth does not include 26 mm for rear bumpers.
Test Standard: EN23953 - Climate Class 3 (25°C, 60% relative humidity).