

Model:  
**TUC-27F-HC**

**Undercounter:**  
*Solid Door Freezer with Hydrocarbon Refrigerant*



## TUC-27F-HC

- ▶ True's undercounter units are designed with enduring quality that protects your long term investment.
- ▶ Designed using the highest quality materials and components to provide the user with colder product temperatures, lower utility costs, exceptional food safety and the best value in today's food service marketplace.
- ▶ Factory engineered, self-contained, capillary tube system using environmentally friendly R290 hydro carbon refrigerant that has zero (0) ozone depletion potential (ODP), & three (3) global warming potential (GWP).
- ▶ Energy Efficient, environmentally friendly forced-air refrigeration system holds -23.3°C, ideally suited for frozen foods..
- ▶ All stainless steel front, top and ends. Corrosion resistant GalFan coated steel back.
- ▶ Interior - attractive, NSF approved, clear coated aluminum liner. Stainless steel floor with coved corners.
- ▶ Front breathing.
- ▶ Heavy duty PVC coated wire shelves.
- ▶ Automatic defrost system time-initiated, time-terminated.
- ▶ Foamed-in-place using a high density, polyurethane insulation that has zero ozone depletion potential (ODP) and zero global warming potential (GWP).

## PLAN VIEW

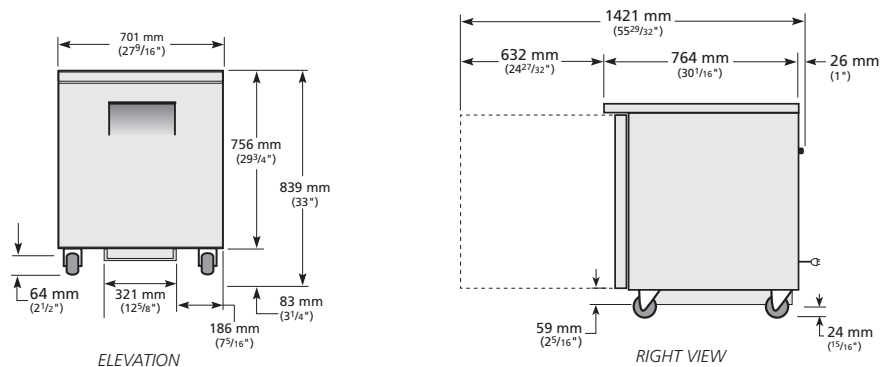

## ROUGH-IN DATA

Voltage: 220-240V/50-60Hz

Specifications subject to change without notice.  
Chart dimensions rounded up to the next whole millimeter (inches rounded up to the next 1/8").

Model	Model Type	Doors	Shelves	Cabinet Dimensions (mm)			Net Volume (litres)	EEC	EEI	24 hr/ Energy Consumption (kWh)	Annual Energy Consumption (kWh)	Crated Weight (kg)
				W	D	H						
TUC-27F-HC	Counter Frozen	1	2	702	766	839	143	C	45.8	4.034	1472	87

† Depth does not include 26 mm for rear bumpers.

Test Standard: EN16825 - Climate Class 5 (40°C, 40% relative humidity).