

Model:  
**TUC-72-HC**

**Undercounter:**  
*Solid Door Refrigerator with Hydrocarbon Refrigerant*

**TUC-72-HC**

- ▶ True's undercounter units are designed with enduring quality that protects your long term investment.
- ▶ Factory engineered system using environmentally friendly R290 hydro carbon refrigerant maintains temperature of 0.5°C to 3.3°C for the best in food preservation.
- ▶ Exterior - stainless steel front, top and ends. GalFan coated steel back.
- ▶ Interior - NSF approved, clear coated aluminum liner. Stainless steel floor with coved corners.
- ▶ Adjustable, heavy duty PVC coated shelves.
- ▶ Foamed-in-place using a high density, environmentally friendly polyurethane insulation.



**PLAN VIEW**

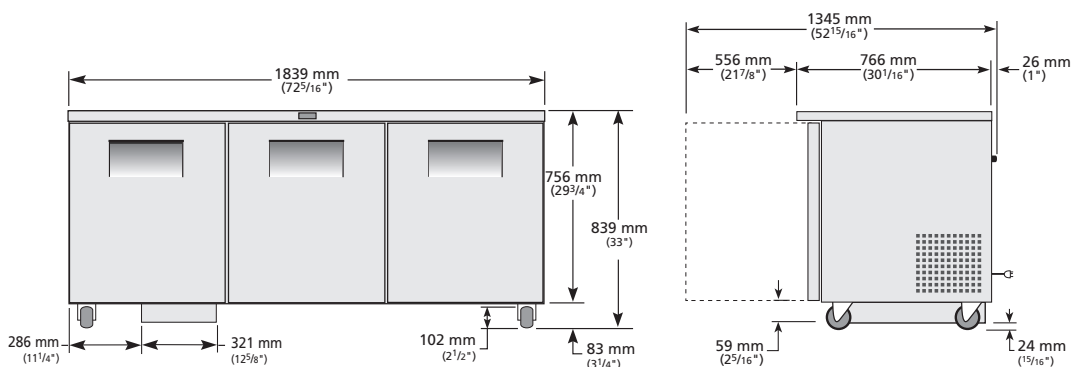

**ROUGH-IN DATA**

Voltage: 220-240V/50-60Hz

Specifications subject to change without notice. Chart dimensions rounded up to the next whole millimeter (inches rounded up to the next 1/8").

Model	Model Type	Doors/Drawers	Shelves	Cabinet Dimensions (mm)			Net Volumes (litres)	EEC	EEI	24 hr/ Energy Consumption (kWh)	Annual Energy Consumption (kWh)	Crated Weight (kg)
				W	D †	H						
TUC-72-HC	Counter Chilled	3/0	6	1839	766	839	461	B	33,2	2,70	985	184

† Depth does not include 26 mm for rear bumpers.  
Test Standard: EN16825 - Climate Class 5 (40°C, 40% relative humidity).