

Model:
TSSU-60-16-DS-ST-HC

Food Prep Table:
Dual Sided Solid Door Sandwich/Salad Unit with Hydrocarbon Refrigerant



TSSU-60-16-DS-ST-HC

- ▶ True's salad/sandwich units are designed with enduring quality that protects your long term investment.
- ▶ Factory engineered, self-contained, capillary tube system using environmentally friendly R290 hydrocarbon refrigerant that has zero (0) ozone depletion potential (ODP), & three (3) global warming potential (GWP).
- ▶ Patented forced-air design holds 33°F to 41°F (.5°C to 5°C) product temperature in food pans and cabinet interior.
- ▶ Complies with ANSI/NSF-7.
- ▶ Exterior - stainless steel front, top and ends. Corrosion resistant GalFan coated steel back.
- ▶ Stainless steel, patented, foam insulated lids keep pan temperatures colder, lock in freshness and minimize condensation. Removable for easy cleaning.
- ▶ Interior - attractive, NSF approved, clear coated aluminum liner. Stainless steel floor with coved corners.
- ▶ 11 ¾" (299 mm) deep, ½" (13 mm) thick, full length removable cutting board included. Sanitary, high density, NSF approved white polyethylene provides tough preparation surface.
- ▶ Heavy duty PVC coated wire shelves.
- ▶ Foamed-in-place using a high density, polyurethane insulation that has zero ozone depletion potential (ODP) and zero global warming potential (GWP).

PLAN VIEW

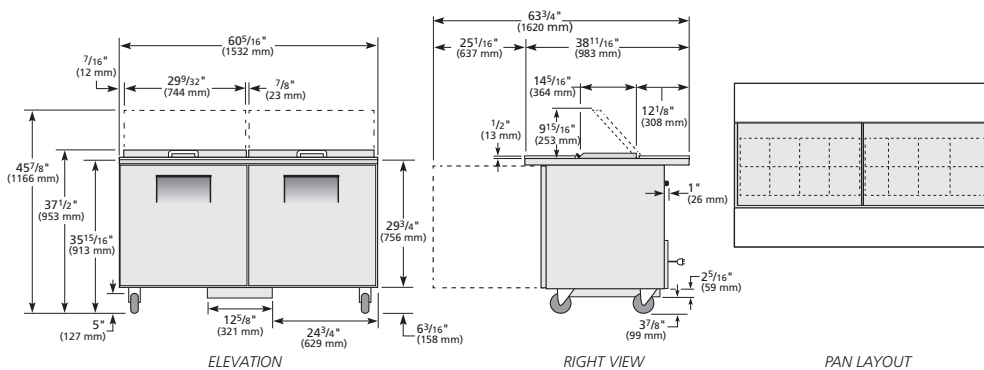

ROUGH-IN DATA

Voltage: 220-240V/50-60Hz

Specifications subject to change without notice.
Chart dimensions rounded up to the next whole millimeter (inches rounded up to the next 1/8").

Model	Doors	Shelves	Pans (top)	Cabinet Dimensions (mm)			HP	Voltage	Amps	Capacity (litres)	Refrigerant	Crated Weight (kg)
				W	D	H						
TSSU-60-16-DS-ST-HC	2	4	16	1534	985	956	1/3	220-240V/50-60Hz	2.2	439	R290	193