

Model:

**TSSU-48-18M-B-FGLID-HC**

**Food Prep Table:**

*Mega-Top Sandwich/Salad Unit with Flat Glass Lid and Hydrocarbon Refrigerant*



## TSSU-48-18M-B-FGLID-HC

- ▶ True's salad/sandwich units are designed with enduring quality that protects your long term investment.
- ▶ Factory engineered, self-contained, capillary tube system using environmentally friendly R290 hydro carbon refrigerant that has zero (0) ozone depletion potential (ODP), & three (3) global warming potential (GWP).
- ▶ Patented forced-air design holds 33°F to 41°F (.5°C to 5°C) product temperature in food pans and cabinet interior.
- ▶ Complies with and listed under ANSI/ NSF-7.
- ▶ All stainless steel front, top and ends. Corrosion resistant GalFan coated steel back.
- ▶ Heavy-duty flat glass lid keeps pan temperatures colder and locks in freshness while enabling maximum product visibility.
- ▶ Interior - attractive, NSF approved, clear coated aluminum liner. Stainless steel floor with coved corners.
- ▶ 6 1/8" (156 mm) deep, 1/2" (13 mm) thick, full length removable cutting board included. Sanitary, high density, NSF approved white polyethylene provides tough preparation surface.
- ▶ Heavy duty PVC coated wire shelves.
- ▶ Foamed-in-place using a high density, polyurethane insulation that has zero ozone depletion potential (ODP) and zero global warming potential (GWP).

## PLAN VIEW

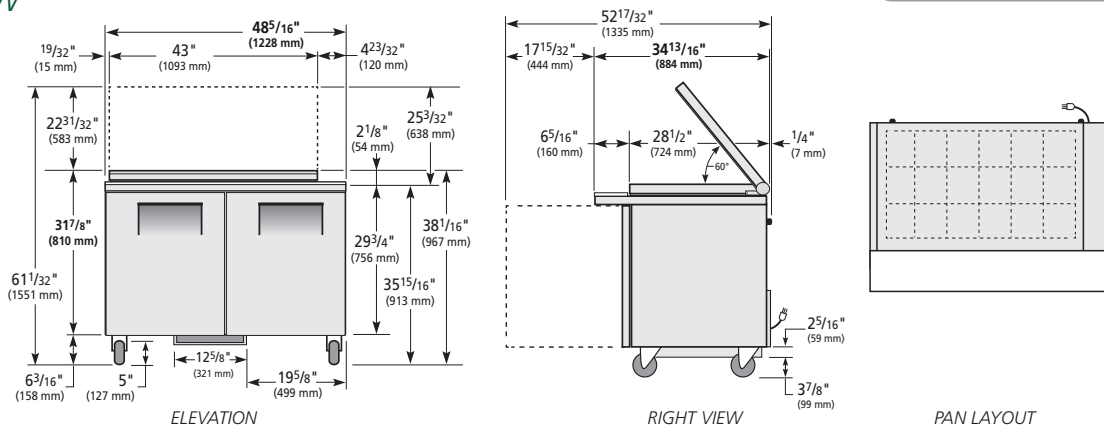

## ROUGH-IN DATA

Voltage: 220-240V/50-60Hz

Specifications subject to change without notice. Chart dimensions rounded up to the next whole millimeter (inches rounded up to the next 1/8").

Model	Doors	Shelves	Cabinet Dimensions (mm)			HP	Voltage	Amps	Capacity (litres)	Refrigerant	Crated Weight (kg)
			W†	D*	H						
TSSU-48-18M-B-FGLID-HC	2	4	1229	884	967	1/3	230-240/50/1	4.2	366	R290	141

† Depth does not include 7 mm for rear bumpers.

\* Height does not include 584 mm for open lid.