

Model:
TSSU-60-16D-2-HC

Food Prep Table:
Solid Door Sandwich/Salad Unit with Hydrocarbon Refrigerant



TSSU-60-16D-2-HC

- ▶ True's salad/sandwich units are designed with enduring quality that protects your long term investment.
- ▶ Factory engineered, self-contained, capillary tube system using environmentally friendly R290 hydrocarbon refrigerant that has zero (0) ozone depletion potential (ODP), & three (3) global warming potential (GWP).
- ▶ Patented forced-air design holds 0.5°C to 5°C product temperature in food pans and cabinet interior.
- ▶ Exterior - stainless steel front, top and ends. Corrosion resistant GalFan coated steel back.
- ▶ Stainless steel, patented, foam insulated lids and hood keep pan temperatures colder, lock in freshness and minimize condensation. Removable for easy cleaning.
- ▶ Interior - attractive, NSF approved, clear coated aluminum liner. Stainless steel floor with coved corners.
- ▶ 299 mm deep, 13 mm thick, full length removable cutting board included. Sanitary, high density, NSF approved white polyethylene provides tough preparation surface.
- ▶ Each drawer accommodates one (1) 1/1GN (W 530mm x D 325 x H 150 mm) food pan (sold separately).
- ▶ Foamed-in-place using a high density, polyurethane insulation that has zero ozone depletion potential (ODP) and zero global warming potential (GWP).

NOTE: Door or drawer assemblies can be located in any section of the cabinet. Location of doors/drawers must be indicated at time of ordering.

PLAN VIEW

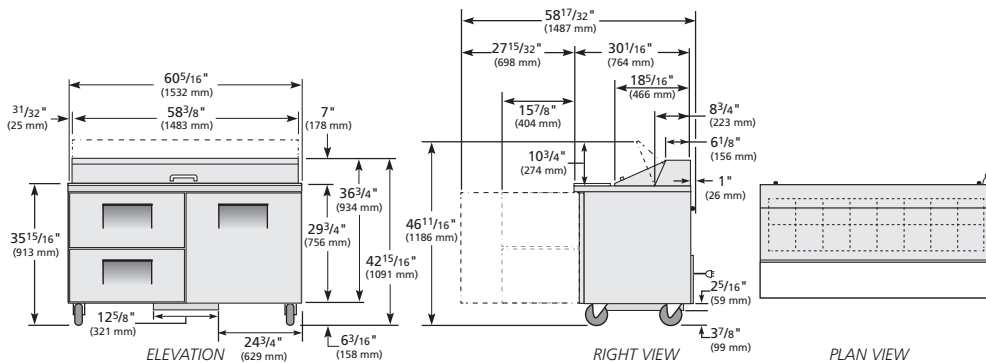

ROUGH-IN DATA

Voltage: 220-240V/50-60Hz

Specifications subject to change without notice. Chart dimensions rounded up to the next whole millimeter (inches rounded up to the next 1/8").

Model	Door/Drawers	Shelves	Pans (top)	Cabinet Dimensions (mm)			HP	Voltage	Amps	Capacity (litres)	Refrigerant	Crated Weight (kg)
				W	D†	H						
TSSU-60-16D-2-HC	1/2	2	16	1534	766	1093	1/3	220-240V/50-60Hz	2.2	439	R290	184

† Depth does not include 26mm for rear bumpers.