

Model:
TPP-AT-44D-2-HC

Food Prep Table:
Pizza Prep Table with Alternate Top, Drawers & Hydrocarbon Refrigerant



TPP-AT-44D-2-HC

- ▶ True's pizza prep tables are designed with enduring quality that protects your long term investment.
- ▶ Factory engineered, self-contained, capillary tube system using environmentally friendly R290 hydro carbon refrigerant that has zero (0) ozone depletion potential (ODP), & three (3) global warming potential (GWP).
- ▶ High capacity, factory balanced environmentally friendly forced-air refrigeration system holds 0.5°C to 5°C.
- ▶ NSF/ANSI Standard 7 compliant for open food product.
- ▶ All stainless steel front, top and ends. Corrosion resistant GalFan coated steel back.
- ▶ Stainless steel, patented, foam insulated flat lids keep pan temperatures colder, lock in freshness, and minimize condensation.
- ▶ Interior - attractive, NSF approved, clear coated aluminum liner. Stainless steel floor with coved corners.
- ▶ Extra-deep 496 mm full length removable cutting board included. Sanitary, high density, NSF approved white polyethylene provides tough preparation surface.
- ▶ Heavy duty, PVC coated wire shelves (door sections).
- ▶ Each drawer accommodates two (2) GN 1/1 pans (W 325 mm x D 530 mm x H 204mm - sold separately).
- ▶ Foamed-in-place using a high density, polyurethane insulation that has zero ozone depletion potential (ODP) and zero global warming potential (GWP).

PLAN VIEW

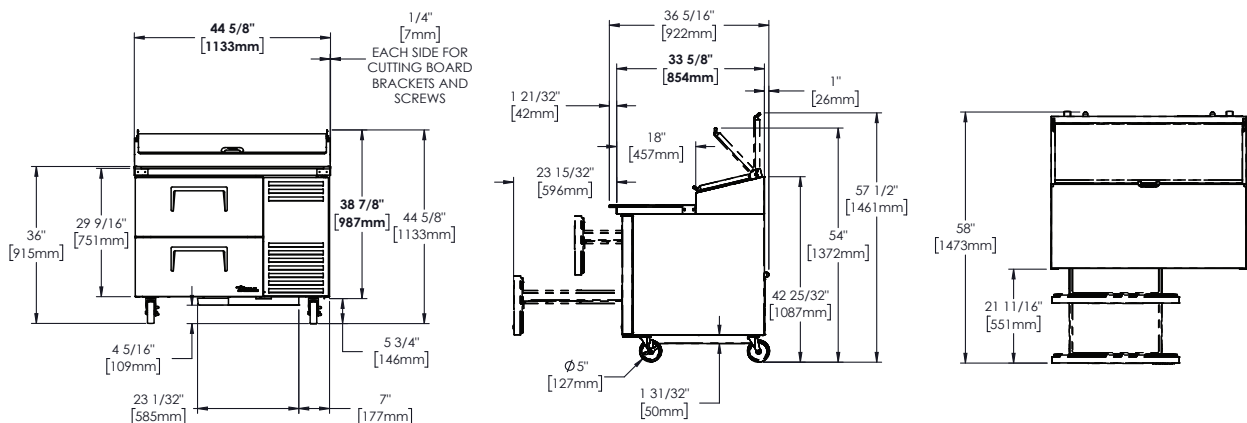

ROUGH-IN DATA

Specifications subject to change without notice.
Chart dimensions rounded up to the next whole millimeter (inches rounded up to the next 1/8").

Model	Doors / Drawers	Shelves	Pans (top)	Cabinet Dimensions (mm)			Voltage	Amps	Net Volume (litres)	Refrigerant	Crated Weight (kg)
				W	D†	H					
TPP-AT-44D-2-HC	0/2	—	6	1134	854	1133	220-240V/50-60Hz	1,8	—	R290	150

† Depth does not include 26 mm for rear bumpers and 44mm for cutting board.