

Model:

TFP-64-24M-FGLID-HC

Food Prep Table:

Food Prep Unit with Flat Glass Lid & Hydrocarbon Refrigerant

TFP-64-24M-FGLID-HC



- ▶ True's food prep units are designed with enduring quality that protects your long term investment.
- ▶ Energy saving, environmentally friendly, exclusive forced-air refrigeration system holds 0.5°C to 5°C.
- ▶ Heavy-duty flat glass lid keeps pan temperatures colder and locks in freshness while enabling maximum product visibility.
- ▶ Exterior - stainless steel front, top and ends. GalFan coated steel back.
- ▶ Interior - attractive, NSF approved, clear coated aluminum liner. Stainless steel floor with coved corners.
- ▶ 204 mm deep, 13 mm thick, full length removable cutting board included. Sanitary, high density, NSF approved white polyethylene provides tough preparation surface.
- ▶ Doors fitted with 305 mm long recessed handle that is foamed-in-place with a sheet metal interlock to ensure permanent attachment.
- ▶ Foamed-in-place using a high density, environmentally friendly polyurethane insulation.

PLAN VIEW

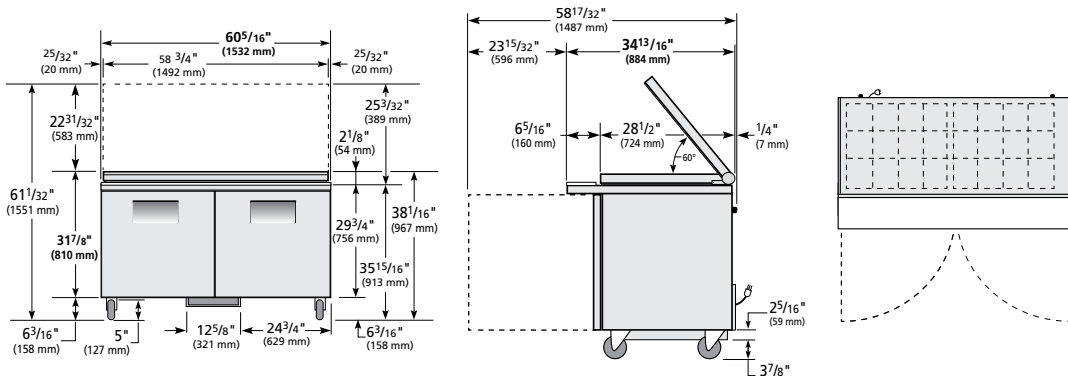

ROUGH-IN DATA

Voltage: 220-240V/50Hz

Specifications subject to change without notice. Chart dimensions rounded up to the next whole millimeter (inches rounded up to the next 1/8").

Model	Doors/Drawers	Shelves	Cabinet Dimensions (mm)			HP	Amps	Pans (top)	Refrigerant	Crated Weight (kg)
			W	D†	H*					
TFP-64-24M-FGLID-HC	2/0	4	1629	820	966	1/4	2,5	24	R290	—

† Depth does not include 51 mm for cutting board.

* Height for all units are with the lid(s) closed.