



### FEATURES

- ▶ R290 Hydrocarbon refrigerant.
- ▶ Temperatures of 33°F to 38°F (.5°C to 3.3°C)
- ▶ Exterior: Stainless steel
- ▶ Interior: Stainless steel
- ▶ Low-E, double pane thermal insulated glass doors
- ▶ RCU Technology
- ▶ White LED interior lighting
- ▶ NSF/ANSI standard 7 compliant for open food product
- ▶ Three (3) interior access ports
- ▶ Self-closing slide doors
- ▶ Zero clearance / Front air intake / front air discharge
- ▶ Electronic temperature control with exterior digital display

### OPTIONS

- ▶ TruLumina® 14-Color LED lighting
- ▶ Castors: 23 mm rollers, 51mm, 77mm, 102mm, 127mm castors
- ▶ 153mm legs
- ▶ 153mm seismic legs
- ▶ Alternative temperature zones available (contact factory)
- ▶ Right side compressor

### PLAN VIEW

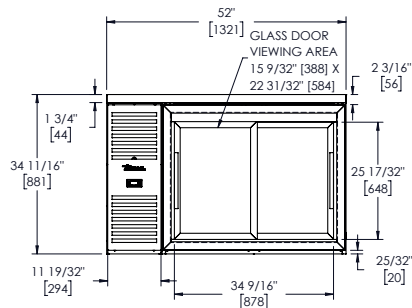

FRONT VIEW

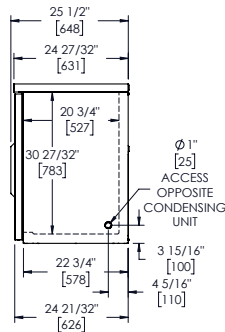

SIDE VIEW

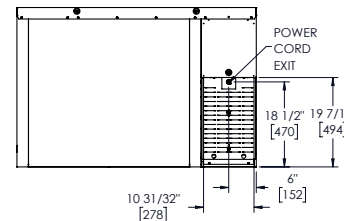

BACK VIEW

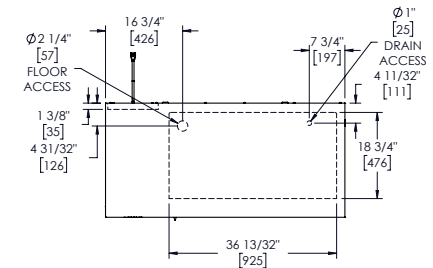

TOP VIEW

### ROUGH-IN DATA

Specifications subject to change without notice. Chart dimensions rounded up to the nearest whole millimeter

Model	Doors	Shelves	Shelf Sizes (mm)	Cabinet Dimensions (mm)			220-240V/50-60Hz		Crated Weight (kg)
				W	D†	H*	HP	Amps	
TBR52-RISZ1-L-S-11-2	2	6	450 x 458	1321	631	881	1/3	1.3	—

† Depth does not include 16 mm for slide door handles. \* Height does not include 7 mm for leg levelers.