

Model:
TAC-27K-HC-LD

Vertical Air Curtains:
Refrigerator with Hydrocarbon Refrigerant & LED Lighting



TAC-27K-HC-LD

- ▶ Large, open front allows easy access to display levels and places maximum attention on merchandising.
- ▶ Factory engineered system using environmentally friendly R290 hydro carbon refrigerant.
- ▶ High capacity, factory balanced refrigeration system that maintains cabinet temperatures of 0.5°C to 3.3°C.
- ▶ Patented reversing condenser fan motors help keeping the condenser coil free from dirt, dust and debris. Regularly scheduled thorough cleaning of coils still recommended.
- ▶ Exterior - Attractive and durable clear aluminum
- ▶ Interior - Stainless steel interior floor and deck pans.
- ▶ Adjustable, heavy duty chrome plated wire shelves.
- ▶ LED interior cabinet lighting
- ▶ Entire cabinet structure is foamed-in-place using a high density, environmentally friendly, polyurethane insulation.

PLAN VIEW

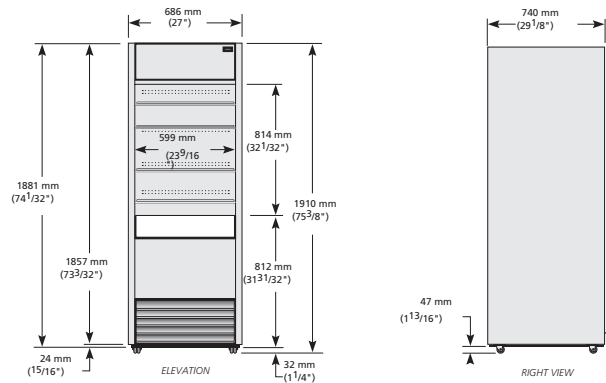

ROUGH-IN DATA

Voltage: 220-240V/50Hz

Specifications subject to change without notice.
Chart dimensions rounded up to the next whole millimeter (inches rounded up to the next 1/8").

Model	Doors	Shelves	Cabinet Dimensions (mm)			Total Display Area (m ²)	EEC	EEI	Temperature Class	Annual Energy Consumption (kWh)	Crated Weight (kg)
			W	D	H						
TAC-27K-HC-LD	—	4	686	740	1910	0,59	D	48,7	M2	2826	152

Test Standard: EN23953 - Climate Class 3 (25°C, 60% relative humidity).