

Model:  
**T-49-HC-LD**

**T-Series:**  
*Reach-In Solid Swing Door Refrigerator with Hydrocarbon Refrigerant*



## T-49-HC-LD

- ▶ True's solid door reach-ins are designed with enduring quality that protects your long term investment.
- ▶ Designed using the highest quality materials and components to provide the user with colder product temperatures, lower utility costs, exceptional food safety and the best value in today's food service marketplace.
- ▶ Factory engineered, self-contained, capillary tube system using environmentally friendly R290 hydro carbon refrigerant that has zero (0) ozone depletion potential (ODP), & three (3) global warming potential (GWP).
- ▶ High capacity, factory balanced refrigeration system that maintains cabinet temperatures of 0.5°C to 3.3°C for the best in food preservation.
- ▶ Stainless steel solid doors and front. The finest stainless available with higher tensile strength for fewer dents and scratches.
- ▶ LED interior lighting provides more even lighting throughout the cabinet. Safety shielded.
- ▶ Adjustable, heavy duty PVC coated shelves.
- ▶ Positive seal self-closing doors. Lifetime guaranteed door hinges and torsion type closure system.

### Bottom mounted units feature:

- ▶ "No stoop" lower shelf.
- ▶ Storage on top of cabinet.
- ▶ Compressor performs in coolest, most grease free area of kitchen.
- ▶ Easily accessible condenser coil for cleaning.

## PLAN VIEW

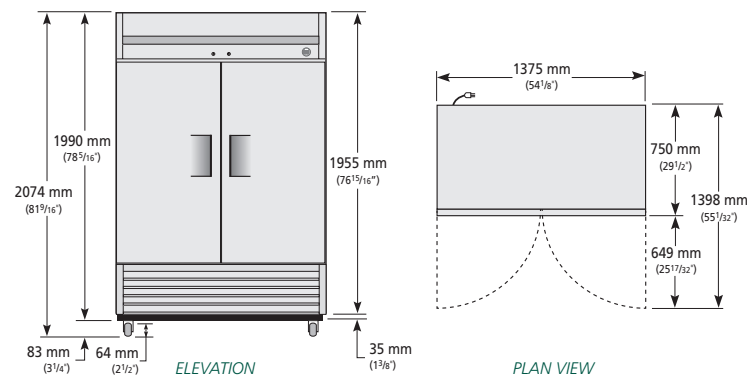

## ROUGH-IN DATA

Voltage: 220-240V/50Hz

Specifications subject to change without notice.  
Chart dimensions rounded up to the next whole millimeter (inches rounded up to the next 1/8").

Model	Model Type	Doors	Shelves	Cabinet Dimensions (mm)			Net Volume (litres)	EEC	EEI	24 hr/ Energy Consumption (kWh)	Annual Energy Consumption (kWh)	Crated Weight (kg)
				W	D	H						
T-49-HC-LD	Vertical Chilled	2	8	1375	750	2074	914	D	73	4.201	1533	177

Test Standard: EN16825 - Climate Class 4 (30°C, 55% relative humidity).