

Model:

GDM-19T-HC~TSL01

Glass Door Merchandiser:

Slide Door Refrigerator with Hydrocarbon Refrigerant & LED Lighting



GDM-19T-HC~TSL01

- ▶ Designed using the highest quality materials and components to provide the user with an attractive, point of purchase merchandiser that brilliantly displays frozen food, resulting in high impulse sales.
- ▶ Factory engineered system using environmentally friendly R290 hydrocarbon refrigerant.
- ▶ High capacity, factory balanced, refrigeration system holds 0.5°C to 3.3°C for best food preservation in extreme conditions.
- ▶ Exterior - non-peel or chip clear coated cold rolled steel; durable and permanent.
- ▶ Interior - NSF approved, white aluminum interior liner with stainless steel floor.
- ▶ Self closing door. Positive seal, torsion type closure system.
- ▶ "Low-E", double pane thermal insulated glass door assembly with extruded aluminum frame. The latest in energy efficient technology.
- ▶ LED interior lighting provides more even lighting throughout the cabinet. Safety shielded.
- ▶ Entire cabinet structure is foamed-in-place using a high density, environmentally friendly, polyurethane insulation.

Bottom mounted units feature:

- ▶ "No stoop" lower shelf
- ▶ Easily accessible condenser coil for cleaning

PLAN VIEW

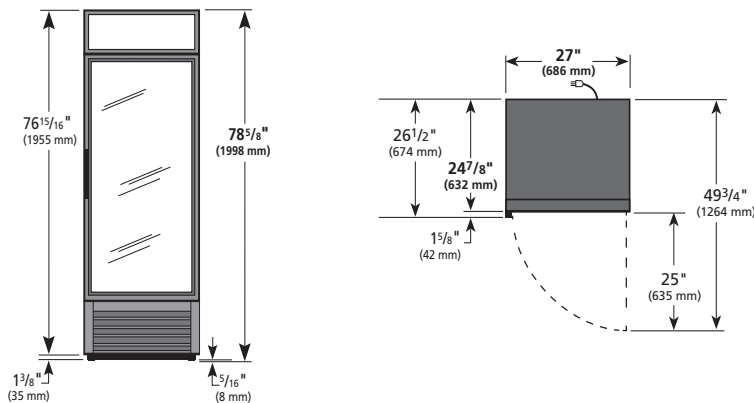

ROUGH-IN DATA

Voltage: 220-240V/50Hz

Specifications subject to change without notice.
Chart dimensions rounded up to the next whole millimeter (inches rounded up to the next 1/8").

Model	Doors	Shelves	Cabinet Dimensions (mm)			Total Display Area (m ²)	EEC	EEI	Temperature Class	Annual Energy Consumption (kWh)	Crated Weight (kg)
			W	D†	H						
GDM-19T-HC~TSL01	1	4	686	632	1998	0.74	B	13,9	M1	1020	143

† Depth does not include 42 mm for door handle(s).

Test Standard: EN23953 - Climate Class 3 (25°C, 60% relative humidity).