

Model:  
**GDM-47-HC-LD**

**Glass Door Merchandiser:**  
*Slide Door Refrigerator with Hydrocarbon Refrigerant & LED Lighting*



**GDM-47-HC-LD**

- ▶ Designed using the highest quality materials and components to provide the user with an attractive, point of purchase merchandiser that brilliantly displays frozen food, resulting in high impulse sales.
- ▶ Factory engineered system using environmentally friendly R290 hydrocarbon refrigerant.
- ▶ High capacity, factory balanced, refrigeration system holds 0.5°C to 3.3°C for best food preservation in extreme conditions.
- ▶ Exterior - non-peel or chip clear coated cold rolled steel; durable and permanent.
- ▶ Interior - NSF approved, white aluminum interior liner with stainless steel floor.
- ▶ Self closing doors. Counter-balanced weight system for smooth, even, positive closing.
- ▶ "Low-E", double pane thermal insulated glass door assembly. The latest in energy efficient technology.
- ▶ LED interior lighting provides more even lighting throughout the cabinet. Safety shielded.
- ▶ Entire cabinet structure is foamed-in-place using a high density, environmentally friendly, polyurethane insulation.

**Bottom mounted units feature:**

- ▶ "No stoop" lower shelf
- ▶ Easily accessible condenser coil for cleaning

**PLAN VIEW**

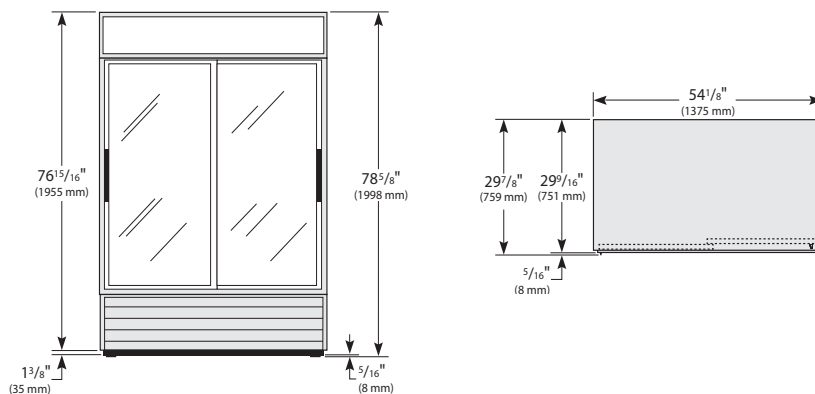

**ROUGH-IN DATA**

Voltage: 220-240V/50Hz

Specifications subject to change without notice.  
Chart dimensions rounded up to the next whole millimeter (inches rounded up to the next 1/8").

Model	Doors	Shelves	Cabinet Dimensions (mm)			Total Display Area (m <sup>2</sup> )	EEC	EEI	Temperature Class	Annual Energy Consumption (kWh)	Crated Weight (kg)
			W	D†	H						
GDM-47-HC-LD	2	8	137	753	1998	1,41	B	18,6	M1	1881	216

† Depth does not include 10 mm for door handles.  
Test Standard: EN23953 - Climate Class 3 (25°C, 60% relative humidity).